

担大任行大道成大事







中德合作，倾力巨献！

China-German cooperation, endeavor contribution!



卓越高效 Excellent and Efficient

- 作业幅度大、起重能力强！
- 转移快捷、作业高效，客户收益最大化
- Larger working radius, stronger lifting capacity!
- Fast transferring, high operation efficiency, optimized customer benefits!

安全可靠 Safe and Reliable

- 38项措施，全方位的安全保障！
- 38 safety provisions, complete safeguard!

节能环保 Energy Saving and Environmental

- 三大节能措施，有效降低使用成本！
- Three energy saving measures decreases operating cost effectively!

先进专业 Advanced and Professional

- 欧洲技术，专业生产！
- European technique, professional manufacturing!

多样齐全 Various and Complete

- 配置多样、型谱齐全！
- Various configurations, complete models!

卓越高效 Excellent and Efficient



作业幅度大、起重能力强，全覆盖行业同吨位产品！ Larger working radius, stronger lifting capacity!



新技术支撑高性能 New technology supports high performance

- 单板式独立臂头
- 紧凑型臂尾
- 四边形大圆弧吊臂
- 臂头重量降低约70%
- 搭接长度增加约30%
- 起重性能提升10%
- Single plate-type independent boom head
- Compact boom tail
- Quadrangular large radius cross-section boom
- Weight of boom head is decreased about 70%
- Overlapping length is increased about 30%
- Lifting capacity is improved 10%

RT50

- > 臂长10.3 ~ 38.2m,全伸臂长超过行业同吨位产品约4m;
- > 中长臂、全伸臂起重性能超过同吨位产品约10% ~ 15%;
- > 作业覆盖率超越同类产品25%左右。
- > Boom length of 10.3 ~ 38.2m, fully-extended boom is about 4m longer than products of the same tonnage;
- > Lifting capacity of mid-extended boom, fully-extended boom is about 10% ~ 15% more than products of the same tonnage;
- > Lifting operation coverage exceeds approximately 25% of similar products.

RT60

- > 臂长11.32 ~ 43.2m,全伸臂长超过行业同吨位产品约8m;
- > 中长臂、全伸臂起重性能超过同吨位产品约10% ~ 25%;
- > 作业覆盖率超越同类产品30%左右。
- > Boom length of 11.32 ~ 43.2m, fully-extended boom is about 8m longer than products of the same tonnage;
- > Lifting capacity of mid-extended boom, fully-extended boom is about 10% ~ 25% more than products of the same tonnage;
- > Lifting operation coverage exceeds approximately 30% of similar products.

转移快捷、作业高效！ Fast transferring, high efficient operation!

- > 带有差速锁的全轮驱动系统、专用的越野轮胎，动力强劲，轻松驶过各种越野路面；
- > 配置带有闭锁功能的液力变矩器，加速性能提升10%，转移快捷；
- > 四种转向模式，正反向行驶功能，转弯半径小于同类产品0.5m以上，无与伦比的机动灵活性；
- > 优化的液压系统、支腿伸缩、起升、变幅、回转速度提升10%，作业高效。
- > All-wheel drive system with differential locks, specific off-road tires and powerful drive make the crane pass through various rough terrains easily.
- > Equipped with locking hydraulic torque converter, acceleration performance is raised 10%, fast job site transferring;
- > Four-steering modes, forwards and backwards driving function, turning radius is at least 0.5m less than similar products, incomparable manoeuvre ability;
- > Optimized hydraulic system, speeds of outrigger extending/retracting, hoisting, elevating and slewing operation are raised 10%, higher operation efficiency.

驱动力、阻力、附着力平衡图 Driving force, resistance, adhesive force

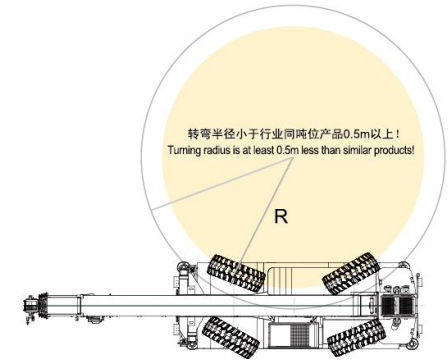
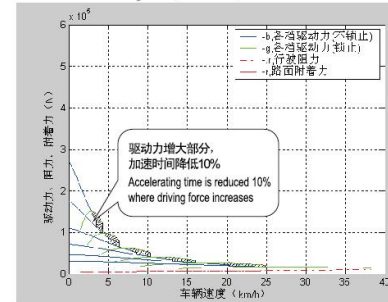

高性能带来高回报 High performance contributes to high benefit

RT80

- > 臂长10.9 ~ 46m,全伸臂长超过行业同吨位产品约7m;
- > 中长臂、全伸臂起重性能超过同吨位产品约10% ~ 15%;
- > 作业覆盖率超越同类产品30%左右。
- > Boom length of 10.9 ~ 46m, fully-extended boom is about 7m longer than products of the same tonnage;
- > Lifting capacity of mid-extended boom, fully-extended boom is about 10% ~ 15% more than products of the same tonnage;
- > Lifting operation coverage exceeds approximately 30% of similar products.

RT100

- > 臂长12.4 ~ 48m,全伸臂长超过行业同吨位产品约3m;
- > 中长臂、全伸臂起重性能超过同吨位产品约10% ~ 20%;
- > 作业覆盖率超越同类产品10%左右。
- > Boom length of 12.4 ~ 48m, fully-extended boom is about 3m longer than products of the same tonnage;
- > Lifting capacity of mid-extended boom, fully-extended boom is about 10% ~ 20% more than products of the same tonnage;
- > Lifting operation coverage exceeds approximately 10% of similar products.

卓越的性能带给您非同凡响的价值体验！
Excellent performance brings extraordinary value experience to you!

安全可靠
Safe and Reliable



38项措施，全方位的安全保障！
38 provisions, complete safety protection!

- > 电源管理、信息通讯采用冗余设计，双重保险；
 - > 多模式故障保护功能：转向系统出现故障时，控制系统能够自动限制发动机的转速，使车辆保持在安全的行驶速度范围内；
 - > 悬架自动刚性锁止功能：转台旋转超过±3°时，系统会自动切换悬架至锁止状态，增加主动安全性；
 - > 完善的强制控制策略：强制功能激活时，按照不同工况强制降速，并发出声光报警，实时监控和提醒。
-
- > Redundant design is adopted in power source management and information communication, double protection;
 - > Multi-mode trouble protective function: control system can automatically limit engine rotational speed when steering system is faulty, consequently the crane may keep driving in safe speed range;
 - > Suspension automatically rigid locking function: system may automatically change suspension to locking state, positive safety is improved;
 - > Well-equipped compulsory control strategy: operation speeds in different working conditions may be decreased when compulsory function is activated, at the same time audible and visual alarm available for real-time monitoring and reminding.
-

人无我有，人有我优！
安全措施多于同类产品5种以上！
操作更省心，使用更放心！

We have what other manufacturers haven't, and ours are better than what they have!
Safety provisions are 5 more than similar products!
Easier to operate, securer to use!

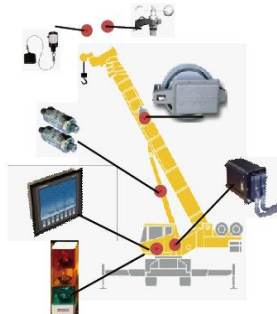

全寿命周期的虚拟仿真和系统性测试、评估，高可靠性的保证！

Virtual and artificial methods are used for system test and evaluation of the crane performance during full life time, the assurance for high reliability of our products!

60年臂架类起重机设计经验的传承与积累，3年多的虚拟仿真和优化设计，辅以多方式、多工况的系统性测试与评估，高可靠性的保证。

Inheritance and accumulation of 60-year's experience in boom crane design, more than 3 years virtual, artificial and optimized design, as well as multi-way system performance test and evaluation in multi-working conditions contribute to high reliability.

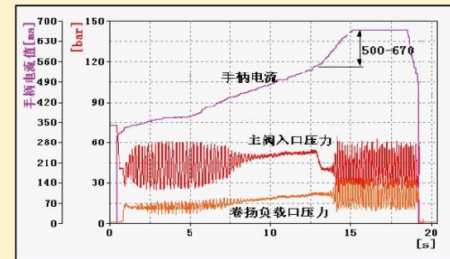
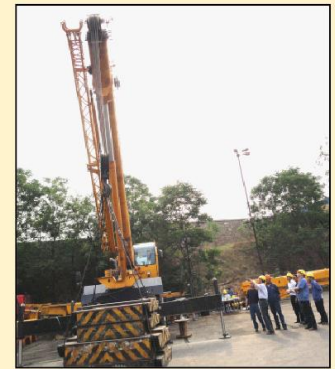
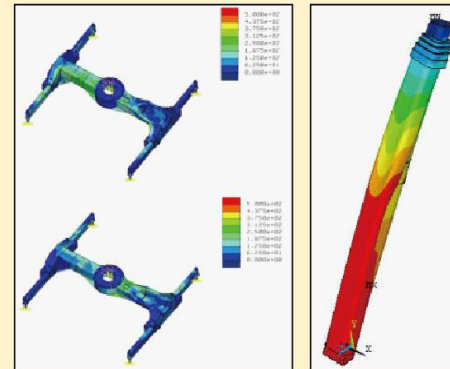

节能环保 Energy Saving and Environmental



三种功率控制工况，Three modes of different power, saves 15% oil!
省油15%!

- 高速工况 ● High speed mode
- 经济作业工况 ● Economic operation mode
- 精细作业工况 ● Refined operation mode

高速行驶时液力变矩器不工作，油耗下降20%
Hydraulic torque converter does not work when traveling in high speed, oil consumption decreases 20%

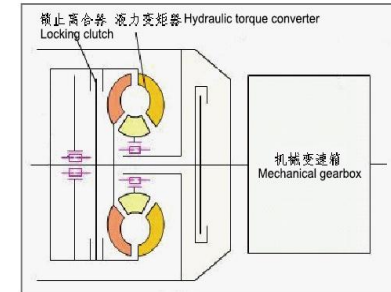
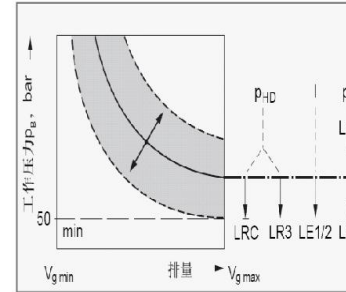

3大节能措施，使用费用低！ Three energy saving measures, low use cost!

- > 电子越权功率控制的液压系统，降低油耗、延长元件使用寿命约15%；
- > 具有闭锁功能的变矩器，高速行驶油耗约降低20%；
- > 变幅系统采用重力下降，无需额外动力，节能、环保。
- > Electronic priority controlled hydraulic system with variable power, which decreases oil consumption and prolongs about 15% of element service life;
- > Torque converter with lockout function, which saves 20% oil in high speed traveling;
- > Elevating system adopts gravity descending without additional power, energy saving and environmental.

绿色环保，噪音小！ Green and environmental, little noise!

- > 产品满足欧三、欧四排放法规要求；
- > 噪音符合欧美等发达国家法律法规要求；驾驶舒适。
- > All products meet Euro III and Euro IV emission standard requirements;
- > Noise conforms to laws and regulations requirements of Euramerican developed countries; comfortable driving.





专业化生产、标准化控制，产品质量过硬！ Professional production, standardized control, and quality product!

- > 世界顶级的现代化板材成型中心，加工精度达0.1mm；
- > 一流的数控加工中心，80%以上的数控加工率，精度高、一致性好；
- > 独有的智能机器人焊接机群，关键部位全部采用自动化焊接，质量稳定；
- > 专业装配线，全面推广定扭装配技术、在线检测技术，高质量的保证；
- > 严密的过程控制、完善的检测手段，产品一次性合格率达99.3%以上。
- > Top class modern plate machining center, accuracy is up to 0.1mm;
- > First class NC machining center, more than 80% NC machining rate with features of higher accuracy and better consistency;
- > Unique intelligent welding robots for automatic welding of key parts make product quality stable;
- > Specialized, modular and standardized assembly, overall spread assembling technology and on-line test technology ensure high quality products;
- > Strict process control and perfect test measure contribute to 99.3%-odd acceptance rate of products.



欧洲技术，30多项专利，技术领先！ European technique, over 30 patents, leading technology!

全系列、全过程中德联合开发，引进欧洲先进的极致化设计理念，30多项专利技术强力支撑产品先进性。
Developed jointly by Chinese and German engineers in the whole course for all series products,
European advanced design concept is introduced, more than 30 patent technologies mark the product out.

- > 基于RTOS（实时操作系统）开发的电液控制系统，操控灵敏，响应迅速；
- > 国内率先使用单板式独立臂头、紧凑型臂尾，性能提高10%左右；
- > 嵌入式大箱形变截面车架，整体强度提高30%以上；
- > 具有车轮自动回正功能的电比例多模式转向系统，有效降低轮胎磨损；
- > 具有自动制动功能的全液压制动系统，安全可靠，使用省心；
- > 抗流量饱和技术的液压系统，有效解决复合动作抖动问题，操作平稳、舒适。

- > Electro hydraulic control system based on RTOS (real-time operating system), sensitive to operate, fast to respond;
- > With single plate-type independent boom head and compact boom tail used firstly in china, performance is improved about 10%;
- > Built-in frame with large box tapered cross-section improves whole strength more than 30%;
- > Electric proportional multi-mode steering system with automatic return function reduces tire wear effectively;
- > Full hydraulic brake system with automatic brake function, safe and reliable, and secure to use;
- > Flow-saturated resistant technology: effectively resolves fluttering problem of complex movements.



多样齐全
Various and Complete



产品系列化、配置多样化，用户全球化！

Series of products, diversification of configuration, globalization of customers!

国内机型
Domestic models

出口机型
Export models

RT50



RT55U

RT55E

RT60



RT70U

RT70E

RT80



RT90U

RT90E

RT100



RT120U

RT120E

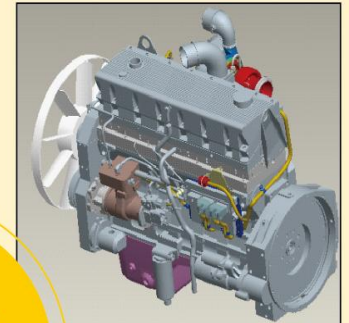

多种配置
Various configurations

多种选择
Various selections



徐工徐工 助您成功
XCMG FOR YOUR SUCCESS



越野轮胎起重机
CASE
施工范例



技术参数 TECHNICAL SPECIFICATIONS

RT50

| 尺寸参数 Dimensions | Unit | |
|---------------------|------|-------|
| 整机全长 Overall length | mm | 12100 |
| 整机全宽 Overall width | mm | 2980 |
| 整机全高 Overall height | mm | 3530 |

| 重量参数 Weight | | |
|--------------------------------------|----|-------|
| 行驶状态整机自重 Dead weight in travel state | kg | 38500 |
| 第一轴轴荷 First axle load | kg | 17750 |
| 第二轴轴荷 Second axle load | kg | 20750 |

| 动力参数 Power | | |
|-----------------------------|-------------|----------|
| 发动机型号 Engine model | | QSB6.7 |
| 发动机额定功率 Engine rated output | kw/(r/min) | 149/2100 |
| 发动机额定扭矩 Engine rated torque | N.m/(r/min) | 740/1500 |

| 行驶参数 Travel | | |
|-----------------------------|------|------|
| 最高行驶速度 Max.travel speed | km/h | ≥35 |
| 最小转弯直径 Min.turning diameter | m | ≤5.5 |
| 最小离地间隙 Min.ground clearance | mm | 460 |
| 接近角 Approach angle | ° | 25.8 |
| 离去角 Departure angle | ° | 21.8 |
| 最大爬坡能力 Max.gradeability | % | ≥55 |

| 主要性能参数 Lifting performance | | |
|---|------|---------|
| 最大额定总起重量 Max.total rated lifting load | t | 50 |
| 最小额定幅度 Min.rated working radius | m | 3 |
| 转台尾部回转半径 Turning radius at swing table tail | mm | 4090 |
| 基本臂最大起重力矩 Base boom max.load moment | kN.m | 1690 |
| 基本臂 Base boom | m | 10.3 |
| 最长主臂 Full-extend boom | m | 38.2 |
| 最长主臂+副臂 Full-extend boom+Jib | m | 55 |
| 纵向支腿距离 Outrigger longitudinal distance span | m | 7.0 |
| 横向支腿距离 Outrigger lateral distance span | m | 7.0/5.8 |

| 工作速度 Working speed | | |
|---|-------|------|
| 起重臂变幅时间 Boom elevating time | s | ≤80 |
| 起重臂伸缩时间 Boom telescoping time | s | ≤120 |
| 最大回转速度 Max.slewing speed | r/min | ≥2.0 |
| 主起升机构最大速度(空载) Main winch max. speed(no load) | m/min | ≥125 |
| 副起升机构最大速度(空载) Auxiliary winch max. speed(no load) | m/min | ≥125 |

RT50主臂性能表 Total rated lifting load for boom

| 支腿全伸, 配重6t Fully-extend outrigger, counter weight 6t | | | | | | | | |
|---|---|------|-------|-------|------|------|------|-----|
| R/L | 10.3 | 13.8 | 17.28 | 22.9 | 29.1 | 35.4 | 38.2 | |
| 2.5 | 55 | | | | | | | |
| 3.0 | 50 | | | | | | | |
| 4.0 | 42 | 36.0 | | | | | | |
| 5.0 | 34.5 | 30.5 | 25.0 | 22 | | | | |
| 6.0 | 28 | 24.5 | 24.0 | 21.3 | 16 | | | |
| 7.0 | 22 | 21.0 | 21.0 | 20.9 | 15.5 | 12 | | |
| 8.0 | | 18.2 | 18.5 | 19.9 | 14.6 | 11.8 | 8.5 | |
| 9.0 | | 15 | 15 | 16.2 | 14.3 | 11.5 | 8.5 | |
| 10.0 | | 12.1 | 12 | 13.2 | 13.2 | 10.4 | 8.1 | |
| 12.0 | | | 8.2 | 9.2 | 9.9 | 7.8 | 7.8 | |
| 14.0 | | | 5.7 | 6.8 | 7.4 | 6.1 | 7.5 | |
| 16.0 | | | | 5.1 | 5.7 | 4.9 | 6.2 | |
| 18.0 | | | | | 3.9 | 4.5 | 3.9 | 5 |
| 20.0 | | | | | | 3.5 | 3.1 | 4 |
| 22.0 | | | | | | 2.8 | 2.5 | 3.3 |
| 24.0 | | | | | | 2.2 | 2 | 2.7 |
| 26.0 | | | | | | | 1.6 | 2.2 |
| 28.0 | | | | | | | 1.3 | 1.7 |
| 速率 Parts of line | 12 | 8 | 7 | 5 | 4 | 3 | 2 | |
| 仰角范围 Angle area | 28.3°~66.6° 29.6°~66.7° 21.4°~68.6° 12.9°~75° 15.8°~77.1° 17°~78.6° 29.3°~78.3° | | | | | | | |
| 吊钩 Hook block | 50t | | | 25t | | | | |
| 钩重 Weight of hook block | 515kg | | | 308kg | | | | |
| 二节臂 | 0% | 50% | 100% | 100% | 100% | 100% | 100% | |
| 三节臂 | 0% | 0% | 0% | 27% | 57% | 87% | 100% | |
| 四节臂 | 0% | 0% | 0% | 27% | 57% | 87% | 100% | |
| 五节臂 | 0% | 0% | 0% | 27% | 57% | 87% | 100% | |

RT50轮胎支撑作业性能表

| 360° 轮胎支撑作业, 不行驶, 配重6t | | | | | |
|----------------------------|---|------|-------|------|------|
| R/L | 10.3 | 13.8 | 117.3 | 22.9 | 29.1 |
| 3.0 | 14.9 | | | | |
| 4.0 | 11 | 10.9 | | | |
| 5.0 | 8.4 | 8.3 | 8.2 | | |
| 6.0 | 6.5 | 6.4 | 6.4 | 7.2 | |
| 7.0 | 4.9 | 4.8 | 4.8 | 5.7 | 6.3 |
| 8.0 | | 3.5 | 3.5 | 4.3 | 4.9 |
| 9.0 | | 2.5 | 2.5 | 3.3 | 3.9 |
| 10.0 | | 1.8 | 1.7 | 2.6 | 3.1 |
| 12.0 | | | | 1.4 | 2 |
| 吊钩 Parts of line | 4 | 3 | 2 | 2 | 2 |
| 仰角范围 Angle area | 28.3°~63.4° 29.6°~66.7° 48°~68.6° 54.7°~72.3° 64.2°~75.1° | | | | |
| 吊钩 Hook block | 25t | | | | |
| 钩重 Weight of hook block | 308kg | | | | |
| 二节臂 | 0% | 50% | 100% | 100% | 100% |
| 三节臂 | 0% | 0% | 0% | 27% | 57% |
| 四节臂 | 0% | 0% | 0% | 27% | 57% |
| 五节臂 | 0% | 0% | 0% | 27% | 57% |

RT50副臂起重性能表 Total rated lifting load for jib

| 主臂长度38.2m, 支腿全伸, 配重6t | | | | | | | | | | | | |
|-------------------------------|----------------------------|-------------------------------|----------------------------|-------------------------------|----------------------------|-------------------------------|----------------------------|-------------------------------|----------------------------|-------------------------------|----------------------------|-------------------------------|
| | | 副臂9m Jib9m | | | | 副臂17m Jib17m | | | | | | |
| | | 副臂安装角 (Jib offset) | | | | | | | | | | |
| 工作幅度 Working radius (m) | 0° | | 20° | | 40° | | 0° | | 20° | | 40° | |
| | 起重量 Lifting Load (t) | 起升高度 Lifting Height (m) | 起重量 Lifting Load (t) | 起升高度 Lifting Height (m) | 起重量 Lifting Load (t) | 起升高度 Lifting Height (m) | 起重量 Lifting Load (t) | 起升高度 Lifting Height (m) | 起重量 Lifting Load (t) | 起升高度 Lifting Height (m) | 起重量 Lifting Load (t) | 起升高度 Lifting Height (m) |
| 12 | 4.0 | 44.6 | 3.8 | 44.3 | | | 2.8 | 53.0 | | | | |
| 14 | 4.0 | 43.9 | 3.8 | 43.6 | 3.2 | 42.3 | 2.5 | 52.4 | | | | |
| 16 | 4.0 | 43.1 | 3.5 | 42.7 | 2.8 | 41.5 | 2.2 | 51.7 | | | | |
| 18 | 3.9 | 42.1 | 3.2 | 41.8 | 2.6 | 40.5 | 1.9 | 50.9 | 1.7 | 50.3 | | |
| 20 | 3.5 | 41.1 | 3.0 | 40.7 | 2.5 | 39.4 | 1.7 | 50.0 | 1.6 | 49.4 | | |
| 22 | 3.2 | 39.9 | 2.8 | 39.5 | 2.3 | 38.1 | 1.4 | 49.0 | 1.5 | 48.4 | 1.4 | 46.2 |
| 24 | 2.7 | 38.6 | 2.6 | 38.2 | 2.2 | 36.8 | 1.2 | 47.9 | 1.3 | 47.3 | 1.3 | 45.0 |
| 26 | 2.3 | 37.1 | 2.2 | 36.7 | 2.0 | 35.2 | 1.1 | 46.8 | 1.2 | 46.1 | 1.2 | 43.8 |
| 28 | 1.8 | 35.5 | 2.0 | 35 | 1.8 | 33.5 | 1.0 | 45.5 | 1.1 | 44.8 | 1.1 | 42.4 |
| 30 | 1.5 | 33.7 | 1.7 | 33.2 | 1.6 | 31.5 | 0.9 | 44.0 | 1.0 | 43.3 | 1.0 | 40.8 |
| 32 | 1.2 | 31.6 | 1.3 | 31.1 | 1.4 | 29.3 | | | 0.9 | 41.7 | 0.9 | 39.1 |
| 34 | | | 1.1 | 28.7 | 1.1 | 26.8 | | | | | | |
| 吊钩重量 Weight of hook block | 4吨吊钩, 100kg | | | | | | | | | | | |

- 表中额定起重量所表示的数值, 是在平整的坚硬地面上本起重机能保证的最大起重量;
- 表中额定起重量包括吊钩和吊具的重量;
- 只允许在5级(风速14.1m/s)风以下进行作业;
- 表中的工作幅度为起重物落地时的幅度, 是包括起重臂变形量在内的实际值, 因而起吊前应考虑起重臂变形量;
- 表中的起重臂长度一定要按照每节臂的伸缩要求进行伸出;
- 轮胎支撑作业时, 必须使悬挂系统处于锁死状态, 并严禁触动任何调整悬挂的按钮;
- 起重臂的仰角必须处于以上各工况表中给定范围内。

技术参数 TECHNICAL SPECIFICATIONS

RT60

| 尺寸参数 Dimensions | Unit | |
|---------------------|------|-------|
| 整机全长 Overall length | mm | 13160 |
| 整机全宽 Overall width | mm | 3180 |
| 整机全高 Overall height | mm | 3750 |

| 重量参数 Weight | | |
|--------------------------------------|----|-------|
| 行驶状态整机自重 Dead weight in travel state | kg | 49000 |
| 第一轴轴荷 First axle load | kg | 25500 |
| 第二轴轴荷 Second axle load | kg | 23500 |

| 动力参数 Power | | |
|-----------------------------|-------------|----------|
| 发动机型号 Engine model | | QSB6.7 |
| 发动机额定功率 Engine rated output | kw/(r/min) | 194/2100 |
| 发动机额定扭矩 Engine rated torque | N.m/(r/min) | 987/1500 |

| 行驶参数 Travel | | |
|-----------------------------|------|------|
| 最高行驶速度 Max.travel speed | km/h | ≥35 |
| 最小转弯直径 Min.turning diameter | m | ≤6.1 |
| 最小离地间隙 Min.ground clearance | mm | 467 |
| 接近角 Approach angle | ° | 20 |
| 离去角 Departure angle | ° | 17.5 |
| 最大爬坡能力 Max.gradeability | % | ≥65 |

| 主要性能参数 Lifting performance | | |
|---|------|---------|
| 最大额定总起重量 Max.total rated lifting load | t | 60 |
| 最小额定幅度 Min.rated working radius | m | 3 |
| 转台尾部回转半径 Turning radius at swing table tail | mm | 4100 |
| 基本臂最大起重力矩 Base boom max.load moment | kN.m | 2075 |
| 基本臂 Base boom | m | 11.32 |
| 最长主臂 Full-extend boom | m | 43.2 |
| 最长主臂+副臂 Full-extend boom+Jib | m | 60.7 |
| 纵向支腿距离 Outrigger longitudinal distance span | m | 7.3 |
| 横向支腿距离 Outrigger lateral distance span | m | 7.2/5.6 |

| 工作速度 Working speed | | |
|---|-------|------|
| 起重臂变幅时间 Boom elevating time | s | ≤90 |
| 起重臂伸缩时间 Boom telescoping time | s | ≤110 |
| 最大回转速度 Max.slewing speed | r/min | ≥2.0 |
| 主起升机构最大速度(空载) Main winch max. speed(no load) | m/min | ≥125 |
| 副起升机构最大速度(空载) Auxiliary winch max. speed(no load) | m/min | ≥125 |

RT60主臂性能表 Total rated lifting load for boom

| 支腿全伸, 配重9t Fully-extend outrigger, counter weight 9t | | | | | | | |
|--|-------|-------|-------|--------|--------|--------|-------|
| R/L | 11.32 | 15.30 | 19.28 | 25.67 | 32.86 | 40.04 | 43.20 |
| 3.0 | 60 | | | | | | |
| 3.5 | 51.7 | 37.5 | | | | | |
| 4.0 | 47.3 | 37.5 | 31.3 | | | | |
| 5.0 | 39.3 | 36.4 | 30.3 | 23.2 | | | |
| 6.0 | 31.7 | 29.1 | 28.1 | 22.7 | 16.1 | | |
| 7.0 | 26.5 | 24.2 | 23.6 | 21.3 | 15.6 | 10.7 | |
| 8.0 | 22.3 | 20.4 | 20.1 | 20.6 | 15.3 | 10.7 | 8.1 |
| 9.0 | 17.0 | 16.5 | 17.0 | 15.2 | 10.3 | 8.1 | |
| 10.0 | 14.9 | 14.6 | 15.2 | 14.7 | 10.0 | 7.8 | |
| 12.0 | 11.8 | 11.6 | 13.1 | 11.8 | 9.0 | 7.6 | |
| 14.0 | | 8.0 | 9.6 | 10.5 | 8.6 | 7.2 | |
| 16.0 | | | 7.0 | 8.0 | 7.4 | 6.9 | |
| 18.0 | | | 5.3 | 6.2 | 6.7 | 6.8 | |
| 20.0 | | | | 3.9 | 4.7 | 5.4 | 5.6 |
| 22.0 | | | | 2.8 | 3.7 | 4.2 | 4.4 |
| 24.0 | | | | | 2.8 | 3.4 | 3.6 |
| 26.0 | | | | | 2.1 | 2.6 | 2.8 |
| 28.0 | | | | | 1.5 | 2.0 | 2.2 |
| 30.0 | | | | | | 1.5 | 1.7 |
| 32.0 | | | | | | 1.1 | 1.3 |
| 34.0 | | | | | | 0.6 | 0.8 |
| 俯角 Parts of line 俯角范围 Angle area | 12 | 9 | 7 | 5 | 4 | 3 | 2 |
| 吊钩 Hook block | 60t | | | | | | 35t |
| 钩重 Weight of hook block | 616kg | | | | | | 297kg |
| 二节臂 | 0% | 50% | 100% | 100% | 100% | 100% | 100% |
| 三节臂 | 0% | 0% | 0% | 26.70% | 56.70% | 86.70% | 100% |
| 四节臂 | 0% | 0% | 0% | 26.70% | 56.70% | 86.70% | 100% |
| 五节臂 | 0% | 0% | 0% | 26.70% | 56.70% | 86.70% | 100% |

RT60轮胎支撑作业性能表

| 360° 轮胎支撑作业, 不行驶, 配重9t | | | | | |
|---|-------|-------|-------|--------|--------|
| R/L | 11.32 | 15.30 | 19.28 | 25.67 | 32.86 |
| 3.0 | 25.5 | | | | |
| 3.5 | 21.6 | 19.9 | | | |
| 4.0 | 18.6 | 17.2 | 16.0 | | |
| 5.0 | 12.8 | 12.3 | 12.1 | 12.3 | |
| 6.0 | 8.9 | 8.5 | 8.2 | 9.7 | 9.8 |
| 7.0 | 6.3 | 5.9 | 5.7 | 7.1 | 8.0 |
| 8.0 | 4.4 | 4.1 | 3.9 | 5.2 | 6.1 |
| 9.0 | | 2.8 | 2.6 | 3.8 | 4.7 |
| 10.0 | | 1.7 | 1.5 | 2.8 | 3.6 |
| 12.0 | | | | 1.2 | 2.0 |
| 14.0 | | | | | 0.9 |
| 俯角 Parts of line 俯角范围 Angle area | 6 | 4 | 4 | 3 | 2 |
| 吊钩 Hook block | | | | | 35t |
| 钩重 Weight of hook block | | | | | 297kg |
| 二节臂 | 0% | 50% | 100% | 100% | 100.0% |
| 三节臂 | 0% | 0% | 0% | 26.70% | 56.70% |
| 四节臂 | 0% | 0% | 0% | 26.70% | 56.70% |
| 五节臂 | 0% | 0% | 0% | 26.70% | 56.70% |

RT60副臂起重性能表 Total rated lifting load for jib

| 工作幅度 Working radius (m) | 副臂9.5m Jib9.5m | | | | | | 副臂17.5m Jib17.5m | | | | | |
|-------------------------------|----------------------------|-------------------------------|----------------------------|-------------------------------|----------------------------|-------------------------------|----------------------------|-------------------------------|----------------------------|-------------------------------|----------------------------|-------------------------------|
| | 副臂安装角 (Jib offset) | | | | | | | | | | | |
| | 0° | | 20° | | 40° | | 0° | | 20° | | 40° | |
| | 起重量 Lifting Load (t) | 起升高度 Lifting Height (m) | 起重量 Lifting Load (t) | 起升高度 Lifting Height (m) | 起重量 Lifting Load (t) | 起升高度 Lifting Height (m) | 起重量 Lifting Load (t) | 起升高度 Lifting Height (m) | 起重量 Lifting Load (t) | 起升高度 Lifting Height (m) | 起重量 Lifting Load (t) | 起升高度 Lifting Height (m) |
| 12 | 5.0 | 50.4 | | | | | | | | | | |
| 14 | 4.7 | 49.7 | 3.6 | 49.4 | | | 2.4 | 58.1 | | | | |
| 16 | 4.4 | 49.0 | 3.4 | 48.7 | 2.9 | 47.4 | 2.3 | 57.5 | | | | |
| 18 | 4.1 | 48.2 | 3.3 | 47.8 | 2.8 | 46.6 | 2.2 | 56.7 | 1.7 | 56.1 | | |
| 20 | 3.9 | 47.2 | 3.1 | 46.9 | 2.6 | 45.6 | 2.1 | 56.0 | 1.7 | 55.3 | | |
| 22 | 3.7 | 46.2 | 3.0 | 45.8 | 2.6 | 44.5 | 2.0 | 55.1 | 1.6 | 54.4 | 1.3 | 52.2 |
| 24 | 3.3 | 45.1 | 2.9 | 44.7 | 2.6 | 43.3 | 1.9 | 54.1 | 1.6 | 53.4 | 1.2 | 51.1 |
| 26 | 2.7 | 43.8 | 2.8 | 43.4 | 2.4 | 42.0 | 1.8 | 53.1 | 1.5 | 52.4 | 1.2 | 50.0 |
| 28 | 2.2 | 42.4 | 2.5 | 42.0 | 2.4 | 40.6 | 1.7 | 51.9 | 1.5 | 51.2 | 1.1 | 48.8 |
| 30 | 1.8 | 40.9 | 2.0 | 40.5 | 2.2 | 38.9 | 1.7 | 50.7 | 1.4 | 49.9 | 1.1 | 47.5 |
| 32 | 1.4 | 39.2 | 1.6 | 38.8 | 1.8 | 37.2 | 1.6 | 49.3 | 1.3 | 48.6 | 1.0 | 46.0 |
| 34 | 1.1 | 37.4 | 1.3 | 36.9 | 1.4 | 35.2 | 1.4 | 47.9 | 1.3 | 47.1 | 1.0 | 44.4 |
| 36 | | | 1.0 | 34.8 | 1.1 | 33.0 | 1.1 | 46.3 | 1.2 | 45.4 | 1.0 | 42.7 |
| 38 | | | | | | | 0.9 | 44.5 | 1.1 | 43.6 | 0.9 | 40.8 |
| 40 | | | | | | | | | 1.0 | 41.7 | 0.9 | 38.7 |
| 俯角范围 Angle area | 49.9°~77.8° | | 49.4°~78.5° | | 50.8°~78.5° | | 49.5°~78.1° | | 54.1°~79.2° | | 57.1°~79.3° | |
| 吊钩重量 Weight of hook block | 5t (100kg) | | | | | | | | | | | |

- 表中额定起重量所表示的数值,是在平整的坚固地面上本起重机能保证的最大起重量;
- 表中额定起重量包括吊钩和吊具的重量;
- 只允许在5级(风速14.1m/s)风以下进行作业;
- 表中的工作幅度为起吊重物落地时的幅度,是包括起重臂变形量在内的实际值,因而起吊前应考虑起重臂变形量;
- 表中的起重臂长度一定要按照每节臂的伸缩要求进行伸出;
- 轮胎支撑作业时,必须使悬挂系统处于锁死状态,并严禁触动任何调整悬挂的按钮;
- 起重臂的俯角必须处于以上各工况表中给定范围内。

技术参数 TECHNICAL SPECIFICATIONS

RT80

| 尺寸参数 Dimensions | | Unit | |
|---|-------------|-----------|--|
| 整机全长 Overall length | mm | 14050 | |
| 整机全宽 Overall width | mm | 3400 | |
| 整机全高 Overall height | mm | 3990 | |
| 重量参数 Weight | | | |
| 行驶状态整机自重 Dead weight in travel state | kg | 58000 | |
| 第一轴轴荷 First axle load | kg | 30350 | |
| 第二轴轴荷 Second axle load | kg | 27650 | |
| 动力参数 Power | | | |
| 发动机型号 Engine model | | QSL8.9 | |
| 发动机额定功率 Engine rated output | kw/(r/min) | 209/2100 | |
| 发动机额定扭矩 Engine rated torque | N.m/(r/min) | 1424/1500 | |
| 行驶参数 Travel | | | |
| 最高行驶速度 Max.travel speed | km/h | ≥36 | |
| 最小转弯直径 Min.turning diameter | m | ≤7 | |
| 最小离地间隙 Min.ground clearance | mm | 440 | |
| 接近角 Approach angle | ° | 22.5 | |
| 离去角 Departure angle | ° | 20 | |
| 最大爬坡能力 Max.gradeability | % | ≥60 | |
| 主要性能参数 Lifting performance | | | |
| 最大额定总起重量 Max.total rated lifting load | t | 80 | |
| 最小额定幅度 Min.rated working radius | m | 3 | |
| 转台尾部回转半径 Turning radius at swing table tail | mm | 4625 | |
| 基本臂最大起重力矩 Base boom max.load moment | kN.m | 3140 | |
| 基本臂 Base boom | m | 11.9 | |
| 最长主臂 Full-extend boom | m | 46 | |
| 最长主臂+副臂 Full-extend boom+Jib | m | 63.5 | |
| 纵向支腿距离 Outrigger longitudinal distance span | m | 7.8 | |
| 横向支腿距离 Outrigger lateral distance span | m | 7.6/6.5 | |
| 工作速度 Working speed | | | |
| 起重臂变幅时间 Boom elevating time | s | ≤110 | |
| 起重臂伸缩时间 Boom telescoping time | s | ≤155 | |
| 最大回转速度 Max.slewing speed | r/min | ≥2.0 | |
| 主起升机构最大速度(空载) Main winch max. speed(no load) | m/min | ≥125 | |
| 副起升机构最大速度(空载) Auxiliary winch max. speed(no load) | m/min | ≥125 | |

RT80主臂性能表 Total rated lifting load for boom

| 支腿全伸, 配重10t, 360° 作业 Fully-extend outrigger, counter weight 10t, 360° operation | | | | | | | |
|--|---|-------|-------|--------|--------|--------|------|
| R/L | 11.9 | 16.16 | 20.42 | 27.25 | 34.93 | 42.6 | 46 |
| 2.5 | *90.0 | | | | | | |
| 3.0 | 80.0 | | | | | | |
| 3.5 | 80.0 | 67.5 | | | | | |
| 4.0 | 78.1 | 62.0 | 50.0 | | | | |
| 5.0 | 63.8 | 55.1 | 47.8 | 34.8 | | | |
| 6.0 | 53.4 | 48.2 | 42.3 | 32.5 | | | |
| 7.0 | 45.3 | 42.4 | 38.4 | 30.9 | 23.5 | | |
| 8.0 | 36.0 | 35.1 | 34.6 | 27.7 | 21.4 | | |
| 9.0 | 27.8 | 27.1 | 26.6 | 24.8 | 19.8 | 16.6 | |
| 10.0 | 21.6 | 21.2 | 23.0 | 18.5 | 15.6 | 13.4 | |
| 12.0 | 14.7 | 14.3 | 16.0 | 16.3 | 14.0 | 12.2 | |
| 14.0 | 10.1 | | 11.7 | 12.7 | 12.1 | 11.1 | |
| 16.0 | 7.3 | | 8.8 | 9.7 | 10.3 | 9.8 | |
| 18.0 | 6.7 | | | 7.6 | 8.2 | 8.4 | |
| 20.0 | 5.1 | | | 6.0 | 6.6 | 6.8 | |
| 22.0 | 3.9 | | | 4.8 | 5.3 | 5.5 | |
| 24.0 | | | | 3.8 | 4.3 | 4.5 | |
| 26.0 | | | | 3.0 | 3.5 | 3.7 | |
| 28.0 | | | | 2.3 | 2.8 | 3.0 | |
| 30.0 | | | | 1.7 | 2.2 | 2.4 | |
| 32.0 | | | | | 1.7 | 1.9 | |
| 34.0 | | | | | 1.3 | 1.4 | |
| 速率 Parts of line | 14 | 10 | 8 | 5 | 4 | 3 | 2 |
| 吊钩面积 Angle area | 24.1°~72.3° 24.1°~72.3° 24.1°~72.3° 24.1°~72.3° 24.1°~72.3° 24.1°~72.3° 24.1°~72.3° | | | | | | |
| 吊钩 Weight of hook block | 80t | | 50t | | | | |
| 吊钩重量 Weight of hook block | 991kg | | 400kg | | | | |
| 二节臂 | 0% | 50% | 100% | 100% | 100% | 100% | 100% |
| 三节臂 | 0% | 0% | 0% | 26.70% | 56.70% | 86.70% | 100% |
| 四节臂 | 0% | 0% | 0% | 26.70% | 56.70% | 86.70% | 100% |
| 五节臂 | 0% | 0% | 0% | 26.70% | 56.70% | 86.70% | 100% |

RT80轮胎支撑作业性能表

| 360° 轮胎支撑作业, 不行驶, 配重10t | | | | |
|---------------------------|-----------|-----------|-----------|-------------|
| R/L | 11.9 | 16.2 | 20.4 | 27.3 |
| 3.0 | 29.0 | | | |
| 4.0 | 22.2 | 21.6 | 21.3 | |
| 5.0 | 17.4 | 16.7 | 16.3 | 17.9 |
| 6.0 | 12.5 | 11.8 | 11.5 | 12.9 |
| 7.0 | 9.3 | 8.7 | 8.3 | 9.7 |
| 8.0 | 7.0 | 6.4 | 6.1 | 7.4 |
| 9.0 | 5.3 | 4.8 | 4.5 | 5.8 |
| 10.0 | 3.5 | | 3.2 | 4.5 |
| 12.0 | 1.6 | | 1.4 | 2.6 |
| 14.0 | 1.3 | | | |
| 速率 Parts of line | 5 | 4 | 4 | 3 |
| 吊钩面积 Angle area | 18.5°~68° | 30.4°~71° | 49°~75.8° | 56.9°~78.3° |
| 吊钩 Weight of hook block | 50t | | | |
| 吊钩重量 Weight of hook block | 400kg | | | |
| 二节臂 | 0% | 50% | 100% | 100% |
| 三节臂 | 0% | 0% | 0% | 26.70% |
| 四节臂 | 0% | 0% | 0% | 26.70% |
| 五节臂 | 0% | 0% | 0% | 26.70% |

RT80副臂起重性能表 Total rated lifting load for jib

| 主臂长度46m, 全伸支腿, 配重10t | | | | | | | | | | | | | |
|---------------------------|----------------------|-------------------------|----------------------|-------------------------|----------------------|-------------------------|----------------------|-------------------------|----------------------|-------------------------|----------------------|-------------------------|--|
| 工作幅度 Working radius (m) | 副臂10.5m Jib10.5m | | | | | | 副臂17.5m Jib17.5m | | | | | | |
| | 副臂安装角 (Jib offset) | | | | | | | | | | | | |
| | 0° | | 15° | | 30° | | 0° | | 15° | | 30° | | |
| | 起重量 Lifting Load (t) | 起升高度 Lifting Height (m) | 起重量 Lifting Load (t) | 起升高度 Lifting Height (m) | 起重量 Lifting Load (t) | 起升高度 Lifting Height (m) | 起重量 Lifting Load (t) | 起升高度 Lifting Height (m) | 起重量 Lifting Load (t) | 起升高度 Lifting Height (m) | 起重量 Lifting Load (t) | 起升高度 Lifting Height (m) | |
| 14 | 6.0 | 53.7 | | | | | 3.4 | 60.4 | | | | | |
| 16 | 5.9 | 53.0 | 4.5 | 52.8 | | | 3.2 | 59.7 | | | | | |
| 18 | 5.8 | 52.2 | 4.2 | 52.1 | 4.1 | 51.3 | 3.1 | 58.9 | 1.9 | 58.6 | | | |
| 20 | 5.2 | 51.4 | 4.0 | 51.2 | 3.9 | 50.4 | 2.9 | 58.1 | 1.8 | 57.8 | 1.6 | 56.6 | |
| 22 | 4.9 | 50.4 | 3.8 | 50.2 | 3.7 | 49.5 | 2.8 | 57.2 | 1.7 | 56.9 | 1.6 | 55.6 | |
| 24 | 4.6 | 49.4 | 3.6 | 49.2 | 3.4 | 48.4 | 2.7 | 56.2 | 1.6 | 55.8 | 1.5 | 54.6 | |
| 26 | 3.8 | 48.2 | 3.4 | 48.0 | 3.2 | 47.2 | 2.5 | 55.1 | 1.6 | 54.8 | 1.3 | 53.5 | |
| 28 | 3.2 | 47.0 | 3.3 | 46.7 | 3.0 | 45.9 | 2.4 | 53.9 | 1.5 | 53.6 | 1.3 | 52.2 | |
| 30 | 2.6 | 45.6 | 2.9 | 45.4 | 2.9 | 44.5 | 2.3 | 52.6 | 1.5 | 52.3 | 1.2 | 50.9 | |
| 32 | 2.1 | 44.1 | 2.3 | 43.8 | 2.5 | 42.9 | 2.0 | 51.2 | 1.4 | 50.9 | 1.2 | 49.5 | |
| 34 | 1.7 | 42.4 | 1.9 | 42.2 | 2.1 | 41.2 | 1.6 | 49.7 | 1.3 | 49.3 | 1.1 | 47.9 | |
| 36 | | | 1.5 | 40.3 | 1.7 | 39.3 | 1.3 | 48.1 | 1.2 | 47.7 | 1.0 | 46.2 | |
| 38 | | | | | 1.3 | 37.2 | | | 1.2 | 45.9 | 1.0 | 44.3 | |
| 40 | | | | | | | | | | | | | |
| 吊钩重量 Weight of hook block | 6吨吊钩 249kg | | | | | | | | | | | | |

- 表中额定起重量所表示的数值, 是在平整的坚固地面上本起重机能保证的最大起重量;
- 表中额定起重量包括吊钩和吊具的重量;
- 只允许在5级(风速14.1m/s)风以下进行作业;
- 表中的工作幅度为起吊重物落地时的幅度, 是包括起重臂变形量在内的实际值, 因而起吊前应考虑起重臂变形量;
- 表中的起重臂长度一定要按照每节臂的伸缩要求进行伸出;
- 轮胎支撑作业时, 必须使悬挂系统处于锁定状态, 并严禁触动任何调整悬挂的按钮;
- 起重臂的仰角必须处于以上各工况表中给定范围内。

技术参数 TECHNICAL SPECIFICATIONS

RT100

| | | | |
|---|---|-------------|-----------|
|  | 尺寸参数 Dimensions | Unit | |
| | 整机全长 Overall length | mm | 14900 |
| | 整机全宽 Overall width | mm | 3500 |
| | 整机全高 Overall height | mm | 3990 |
|  | 重量参数 Weight | | |
| | 行驶状态整机自重 Dead weight in travel state | kg | 76830 |
| | 第一轴轴荷 First axle load | kg | 41710 |
| | 第二轴轴荷 Second axle load | kg | 35120 |
|  | 动力参数 Power | | |
| | 发动机型号 Engine model | | QSL8.9 |
| | 发动机额定功率 Engine rated output | kw/(r/min) | 224/2100 |
| | 发动机额定扭矩 Engine rated torque | N.m/(r/min) | 1369/1500 |
|  | 行驶参数 Travel | | |
| | 最高行驶速度 Max.travel speed | km/h | ≥33 |
| | 最小转弯直径 Min.turning diameter | m | ≤7.5 |
| | 最小离地间隙 Min.ground clearance | mm | 568 |
| | 接近角 Approach angle | ° | 21.1 |
| | 离去角 Departure angle | ° | 17.3 |
| | 最大爬坡能力 Max.gradeability | % | ≥60 |
|  | 主要性能参数 Lifting performance | | |
| | 最大额定总起重量 Max.total rated lifting load | t | 100 |
| | 最小额定幅度 Min.rated working radius | m | 3 |
| | 转台尾部回转半径 Turning radius at swing table tail | mm | 4930 |
| | 基本臂最大起重力矩 Base boom max.load moment | kN.m | 3500 |
| | 基本臂 Base boom | m | 12.4 |
| | 最长主臂 Full-extend boom | m | 48 |
| | 最长主臂+副臂 Full-extend boom+Jib | m | 68.6 |
| | 纵向支腿距离 Outrigger longitudinal distance span | m | 8.4 |
| | 横向支腿距离 Outrigger lateral distance span | m | 8.2/6.0 |
|  | 工作速度 Working speed | | |
| | 起重臂变幅时间 Boom elevating time | s | ≤95 |
| | 起重臂伸缩时间 Boom telescoping time | s | ≤150 |
| | 最大回转速度 Max.slewing speed | r/min | ≥2.0 |
| | 主起升机构最大速度(空载) Main winch max. speed(no load) | m/min | ≥125 |
| | 副起升机构最大速度(空载) Auxiliary winch max. speed(no load) | m/min | ≥125 |

- 表中额定起重量所表示的数值，是在平整的坚硬地面上本起重量能够保证的最大起重量；
- 表中额定起重量包括吊钩和吊具的重量；
- 只允许在5级（风速14.1m/s）风以下进行作业；
- 表中的工作幅度为起吊重物落地时的幅度，是包括起重臂变形量在内的实际值，因而起吊前应考虑起重臂变形量；
- 表中的起重臂长度一定要按照每节臂的伸缩要求进行伸出；
- 轮胎支撑作业时，必须使悬挂系统处于锁定状态，并严禁触动任何调整悬挂的按钮；
- 起重臂的仰角必须处于以上各工况表中给定范围内。

RT100主臂性能表 Total rated lifting load for boom

| 支腿全伸，配重18t Fully-extend outrigger, counter weight 18t | | | | | | | |
|--|------|-------|------|--------|--------|--------|------|
| R/L | 12.4 | 16.85 | 21.3 | 28.43 | 36.44 | 44.45 | 48 |
| 3.0 | 100 | | | | | | |
| 3.5 | 91 | 76 | | | | | |
| 4.0 | 84 | 72 | 61 | | | | |
| 5.0 | 70 | 62 | 56 | 41.6 | | | |
| 6.0 | 52 | 52 | 50 | 37.6 | 28.9 | | |
| 7.0 | 44 | 44 | 44 | 34.5 | 26.5 | | |
| 8.0 | 37 | 37 | 37 | 31.8 | 24.5 | 19.6 | |
| 9.0 | 31 | 34 | 34 | 29.5 | 22.7 | 18.5 | 14.5 |
| 10.0 | | 29.2 | 28.6 | 27.5 | 21.1 | 17.5 | 14 |
| 12.0 | | 19.8 | 19.3 | 21.6 | 18.5 | 15.7 | 12.6 |
| 14.0 | | | 13.7 | 15.8 | 16.4 | 14.3 | 12 |
| 16.0 | | | | 9.9 | 11.9 | 13.2 | 13 |
| 18.0 | | | | | 9.1 | 10.3 | 11.1 |
| 20.0 | | | | | | 7 | 8.2 |
| 22.0 | | | | | | | 5.3 |
| 24.0 | | | | | | | |
| 26.0 | | | | | | | |
| 28.0 | | | | | | | |
| 30.0 | | | | | | | |
| 32.0 | | | | | | | |
| 34.0 | | | | | | | |
| 36.0 | | | | | | | |
| 38.0 | | | | | | | |
| 吊钩重量 Hook block | 14 | 10 | 8 | 5 | 4 | 3 | 2 |
| 吊钩重量 Hook block | 100t | 70t | 25t | 1185kg | 960kg | 500kg | |
| 二节臂 | 0% | 50% | 100% | 100% | 100% | 100% | 100% |
| 三节臂 | 0% | 0% | 0% | 26.70% | 56.70% | 86.70% | 100% |
| 四节臂 | 0% | 0% | 0% | 26.70% | 56.70% | 86.70% | 100% |
| 五节臂 | 0% | 0% | 0% | 26.70% | 56.70% | 86.70% | 100% |

RT100轮胎支撑作业性能表

| 360° 轮胎支撑作业，不行驶，配重18t | | | | | |
|-----------------------|-------|-------|-------|--------|--------|
| R/L | 12.40 | 16.85 | 21.30 | 28.43 | 36.44 |
| 3.0 | 43.0 | | | | |
| 3.5 | 36.0 | 33.0 | | | |
| 4.0 | 31.0 | 29.0 | 25.0 | | |
| 5.0 | 25.0 | 22.9 | 21.1 | 20.9 | |
| 6.0 | 17.9 | 17.1 | 16.6 | 16.9 | |
| 7.0 | 13.4 | 12.6 | 12.1 | 13.8 | 13.8 |
| 8.0 | 10.2 | 9.5 | 9 | 10.8 | 11.6 |
| 9.0 | 7.8 | 7.1 | 6.7 | 8.5 | 9.6 |
| 10.0 | | 5.3 | 4.9 | 6.6 | 7.8 |
| 12.0 | | | 2.7 | 2.4 | 4 |
| 14.0 | | | | | 2.2 |
| 16.0 | | | | | |
| 吊钩重量 Hook block | 6 | 5 | 4 | 3 | 2 |
| 吊钩重量 Hook block | 70t | 25t | 960kg | 500kg | |
| 二节臂 | 0% | 50% | 100% | 100% | 100% |
| 三节臂 | 0% | 0% | 0% | 26.70% | 56.70% |
| 四节臂 | 0% | 0% | 0% | 26.70% | 56.70% |
| 五节臂 | 0% | 0% | 0% | 26.70% | 56.70% |

RT100副臂起重性能表 Total rated lifting load for jib

| 支腿全伸，主臂长度48m，配重18t | | | | | | |
|-------------------------------|----------------------------|----------------------------|----------------------------|----------------------------|----------------------------|----------------------------|
| 工作幅度 Working radius (m) | 副臂11.8m Jib11.8m | | | 副臂20.6m Jib20.6m | | |
| | 副臂安装角 (Jib offset) | | | | | |
| | 0° | 20° | 40° | 0° | 20° | 40° |
| | 起重量 Lifting Load (t) | 起重量 Lifting Load (t) | 起重量 Lifting Load (t) | 起重量 Lifting Load (t) | 起重量 Lifting Load (t) | 起重量 Lifting Load (t) |
| 14 | 7.0 | | | 3.9 | | |
| 16 | 6.4 | 5.0 | | 3.7 | | |
| 18 | 6.0 | 4.6 | | 3.4 | 2.6 | |
| 20 | 5.8 | 4.4 | 3.4 | 3.3 | 2.5 | |
| 22 | 5.4 | 4.2 | 3.3 | 3.2 | 2.4 | 2.1 |
| 24 | 5.1 | 4.1 | 3.2 | 3.1 | 2.3 | 2.0 |
| 26 | 4.9 | 4.0 | 3.2 | 2.9 | 2.3 | 1.9 |
| 28 | 4.7 | 3.8 | 3.1 | 2.8 | 2.2 | 1.8 |
| 30 | 4.0 | 3.7 | 3.0 | 2.7 | 2.1 | 1.7 |
| 32 | 3.3 | 3.5 | 2.9 | 2.5 | 2.0 | 1.6 |
| 34 | 2.7 | 3.2 | 2.8 | 2.3 | 1.9 | 1.5 |
| 36 | 2.1 | 2.6 | 2.7 | 1.8 | 1.8 | 1.4 |
| 38 | 1.7 | 2.0 | 2.3 | 1.3 | 1.7 | 1.3 |
| 吊钩重量 Weight of hook block | 245kg | | | | | |

技术参数 TECHNICAL SPECIFICATIONS

RT150

| 尺寸参数 Dimensions | | Unit | |
|--|----------|------|---|
| 外形尺寸(长×宽×高) Outline dimension(L×W×H) | mm | | 16350×3570×4100 |
| 支腿跨距(纵/横) Outrigger span (longitudinal/lateral) | mm | | 9200/8500 |
| 基本臂臂长 Base boom length | mm | | 13200 |
| 主臂最长 Boom length | mm | | 62000 |
| 副臂最长 Jib length | mm | | 20000 |
| 吊臂最大/最小仰角 Max./min.boom angle | ° | | 80/-1.5 |
| 最小离地间隙 Min. ground clearance | mm | | 580 |
| 接近角/离去角 Approach angle/Departure angle | ° | | 21.3/16.4 |
| 重量参数 Weight | | | |
| 整车整备质量(不含拆卸配重) Curb mass(excluding self-removable counterweight) | kg | | 66000 |
| 发动机 Engine | | | |
| 型号 Model | | | 康明斯CumminsQSL8.9 |
| 功率/转速 Power/rotation speed | kW/r/min | | 224/2100 |
| 行驶性能参数 Traveling performance | | | |
| 最高行驶速度 Max. travel speed | km/h | | 33 |
| 驱动方式 Drive mode | | | 4×2、4×4 |
| 最大爬坡度 Max. grade-ability | % | | 60% |
| 最小转弯直径 Min. turning radius | m | | 8.5 (四轮Four wheels)、13.5 (两轮Two wheels) |
| 作业性能参数 Lifting Performance | | | |
| 最大额定起重量 Max. rated lifting capacity | kg | | 150000 |
| 基本臂最大起重力矩 Max. load moment for base boom | kN.m | | 5250 |
| 最长主臂最大起重力矩 Max. load moment for fully-extended boom | kN.m | | 2340 |
| 基本臂最大起升高度 Max. lifting height for base boom | mm | | 14300 |
| 主臂最大起升高度 Max. lifting height for boom | mm | | 61400 |
| 副臂最大起升高度 Max. lifting height for jib | mm | | 81000 |
| 主起升机构最大起升速度 Max. hoisting speed for main winch | m/min | | 100 |
| 副起升机构最大起升速度 Max. hoisting speed for auxiliary winch | m/min | | 100 |
| 起重臂变幅时间 Boom elevating time | s | | 105 |
| 起重臂伸缩时间 Boom telescoping time | s | | 600 |
| 最大回转速度 Max. slewing speed | r/min | | 1.8 |
| 水平支腿同时伸缩时间 Outrigger beam extending/retracting simultaneously | s | | 40/30 |
| 垂直支腿同时伸缩时间 Outrigger jacks extending/retracting simultaneously | s | | 55/40 |

起重性能表 TOTAL RATED LIFTING LOAD

| RT150 支腿作业额定起重量表(t) Rated lifting load for boom with the crane on outriggers(t) | | | | | | | | | | | | |
|--|------|------|------|------|------|------|------|------|------|------|------|------|
| 28吨平衡重, 支腿全伸, 360° 作业 With 28t of counterweight, on fully-extended outriggers, 360° operation of the boom | | | | | | | | | | | | |
| R/L | 13.2 | 17.6 | 22.0 | 26.4 | 30.8 | 35.2 | 39.6 | 43.9 | 48.3 | 52.7 | 57.1 | 62.0 |
| 2.5 | 150 | | | | | | | | | | | |
| 3 | 130 | 98.0 | | | | | | | | | | |
| 4 | 120 | 92.0 | 81 | | | | | | | | | |
| 5 | 105 | 85.5 | 73 | 65 | | | | | | | | |
| 6 | 85.0 | 75.0 | 66 | 64 | 54 | | | | | | | |
| 7 | 68.0 | 66.0 | 60 | 60 | 52 | 41 | | | | | | |
| 8 | 58.0 | 57.5 | 56 | 55 | 48 | 40 | 31.5 | | | | | |
| 9 | 50.5 | 48.5 | 48 | 47 | 45 | 36 | 31 | | | | | |
| 10 | 48.5 | 47.5 | 46 | 45 | 39 | 34 | 29 | 25.5 | | | | |
| 12 | | 34.9 | 35.4 | 36.2 | 33 | 32 | 27 | 23.5 | 20 | 16.7 | | |
| 14 | | 26.1 | 26.6 | 27.4 | 28.2 | 27 | 24 | 22 | 18 | 15.3 | 13.5 | |
| 16 | | | 20.8 | 21.5 | 22.4 | 23.2 | 21 | 20 | 17 | 13.9 | 12.5 | 11.5 |
| 18 | | | 16.7 | 17.4 | 18.2 | 19 | 18 | 18 | 15 | 13.3 | 12.1 | 11.5 |
| 20 | | | | 14.3 | 15.1 | 15.9 | 15.3 | 15.3 | 14 | 12.4 | 11.5 | 10.7 |
| 22 | | | | 11.9 | 12.7 | 13.4 | 12.9 | 12.9 | 12.5 | 11.5 | 11.2 | 9.8 |
| 24 | | | | | 10.8 | 11.5 | 11 | 11 | 11 | 10.5 | 10.1 | 9.5 |
| 26 | | | | | 9.2 | 9.9 | 9.4 | 9.4 | 9.6 | 9.5 | 9 | 8.5 |
| 28 | | | | | | 8.6 | 8.1 | 8.1 | 8.3 | 8.6 | 8.5 | 8.3 |
| 30 | | | | | | 7.5 | 7 | 7 | 7.2 | 7.5 | 7.8 | 7.8 |
| 32 | | | | | | | 6.1 | 6 | 6.2 | 6.5 | 6.9 | 7 |
| 34 | | | | | | | 5.2 | 5.2 | 5.4 | 5.7 | 6.1 | 6.1 |
| 36 | | | | | | | | 4.5 | 4.7 | 5 | 5.4 | 5.4 |
| 38 | | | | | | | | | 4.1 | 4.4 | 4.7 | 4.8 |
| 40 | | | | | | | | | 3.5 | 3.8 | 4.2 | 4.2 |
| 42 | | | | | | | | | | 3.3 | 3.7 | 3.7 |
| 44 | | | | | | | | | | 2.8 | 3.2 | 3.2 |
| 46 | | | | | | | | | | | 2.8 | 2.8 |
| 48 | | | | | | | | | | | 2.4 | 2.5 |
| 50 | | | | | | | | | | | | 2.1 |
| 52 | | | | | | | | | | | | 1.8 |
| 54 | | | | | | | | | | | | 1.5 |

| RT150 轮胎支腿作业额定起重量表(不行驶)(t) RT150 Rated lifting load for boom with the crane on tires, stationary(t) | | | | |
|---|------|------|------|------|
| 28吨配重 带支腿, 轮胎支腿作业不行驶, 360° 作业 With 28t of counterweight and outrigger, on tires, stationary 360° operation of the boom | | | | |
| R/L | 13.2 | 17.6 | 22.0 | 26.4 |
| 3 | 49.9 | 51.2 | | |
| 4 | 39.2 | 40.4 | 41.2 | |
| 5 | 31.8 | 33.1 | 33.8 | 34.5 |
| 6 | 26.4 | 27.7 | 28.4 | 29.1 |
| 7 | 22.2 | 23.5 | 24.3 | 25.0 |
| 8 | 18.2 | 19.7 | 20.6 | 21.3 |
| 9 | 14.9 | 16.4 | 17.2 | 17.9 |
| 10 | 12.4 | 13.9 | 14.7 | 15.3 |
| 12 | | 10.2 | 11.0 | 11.6 |
| 14 | | 7.7 | 8.5 | 9.1 |
| 16 | | | 6.6 | 7.3 |
| 18 | | | 5.2 | 5.9 |

| 轮胎支腿作业额定起重量表(行驶速度≤2km/h)(t) RT150 Rated lifting load for boom with the crane on tires (t) | | | | |
|--|-------|-------|-------|-------|
| 28吨配重 带支腿 带载行驶 正前方作业 行驶速度≤2km/h With 28t of counterweight and outrigger, on tires, boom over front, travel speed ≤2km/h | | | | |
| R/L | 13.2 | 17.6 | 22.0 | 26.4 |
| 3 | 33.3 | 34.47 | | |
| 4 | 25.83 | 26.91 | 27.63 | |
| 5 | 20.61 | 21.78 | 22.41 | 23.04 |
| 6 | 16.83 | 18.0 | 18.72 | 19.26 |
| 7 | 13.95 | 15.12 | 15.84 | 16.38 |
| 8 | 11.61 | 12.87 | 13.5 | 14.13 |
| 9 | 9.72 | 10.98 | 11.7 | 12.24 |
| 10 | 8.19 | 9.45 | 10.17 | 10.8 |
| 12 | | 7.11 | 7.83 | 8.46 |
| 14 | | 5.31 | 6.12 | 6.66 |
| 16 | | | 4.77 | 5.31 |
| 18 | | | 3.69 | 4.32 |